



## Standard capsule pressure gauges KP63

Part no. 35016351

Standard capsule pressure gauges Type D3

### benefits

- with zero correction
- ideal for low pressure ranges
- GOSSTANDART-certified

### Application

For gaseous, dry media which do not attack copper alloys.

! For measuring gas or vapour, observe the table "Selection Criteria as per EN 837-2" (see appendix)!

### Technical Specifications

#### Type

D3

#### Nominal size

63

#### accuracy class (EN 837-3/6)

1.6

#### ranges (EN 837-3/5)

see ordering table

#### application area

static load: Full scale value  
dynamic load: 0.9 x full scale value  
overload safety: 1.3 x full scale value

#### Operating temperature range

Medium: max. 60 °C  
Ambient: -20/+60 °C

#### Temperature performance

Indication error when the temperature of the measuring system deviates from the normal temperature of 20 °C:  
at rising temperature approx.  $\pm 0.6 \%$ /10 K  
falling temperature approx.  $\pm 0.6 \%$ /10 K  
of full scale value

#### Degree of protection

NG 63  
IP 33 (EN 60529)

#### Connection

Brass, centre back

#### Measuring element

Capsule element, CuBe alloy

#### movement

Brass

#### Zero correction

from the front

**Seal**  
NBR (Perbunan)

**Housing**  
Stainless steel 304

**Dial**  
Aluminium, white  
Scaling: black

**window**  
Plastic, clipped in

**Pointer**  
Aluminium, black

**Options**

- back flange
- Panel mounting bezel
- 3-hole fixing, panel mounting bezel
- Measuring system stainless steel (NG 100)
- throttle screw
- Reference pointer
- special scales
- other process connections

**Technical Drawings**

**centre back connection, crimped bezel housing with clamp fixing, NG 63**

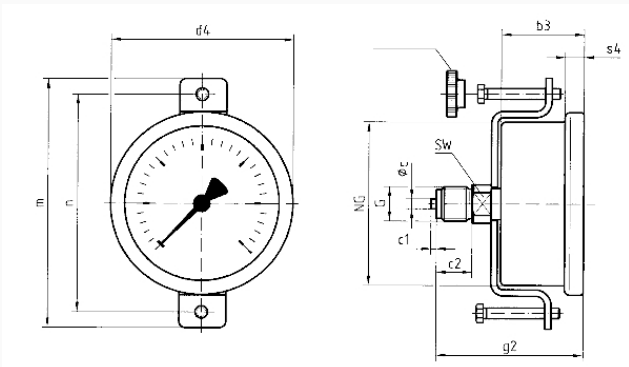

**Dimensions (mm)**

NG	b3	$\varnothing c$	c1	c2	d4	G	g2	m	n	s4	SW
63	30,5	5	2	13	68	G $\frac{1}{4}$ B	53,5	94	82	7	14

**Versions**

Range	Mounting type	Type	Part number
0/25 mbar	Panel mounting bezel, with clamp fixing	KP63 D351	35016351

- in-stock items
- Non-stock items